

DE-CVT DIRECT ACTING CHECK VALVE THERMAL RELIEF, POPPET

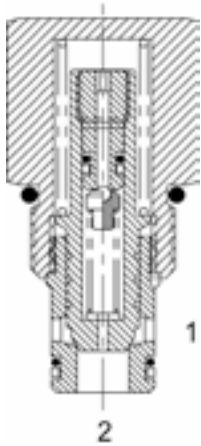

DESCRIPTION

10 size, 7/8-14 thread, "Delta" series, direct acting check valve with thermal relief.

OPERATION

The DE-CVT allows free flow passage from (2) to (1), and blocks flow from (1) to (2). If the pressure at (1) exceeds the thermal relief valve setting, a small amount of oil will be allowed to pass from (1) to (2), preventing cylinder damage from excessive pressure. The cartridge has a fully guided poppet, which is spring biased closed until sufficient pressure is applied at (2) to open to (1).

Note: the relief valve feature is not intended for use in dynamic pressure limiting applications. Consult factory.

FEATURES

- Hardened parts for long life.
- Optional bias springs for backpressure application flexibility.
- Fully guided poppet assembly.
- Industry common cavity.



Nominal flow rating is 15 GPM for free flow port (2) to (1). Consult chart for free flow differential pressure. Thermal relief is cyclic rated to 0.1 GPM. Port (1) to (2) chart demonstrates override characteristics for a typical thermal relief application.

PERFORMANCE

Actual Test Data (Cartridge Only)

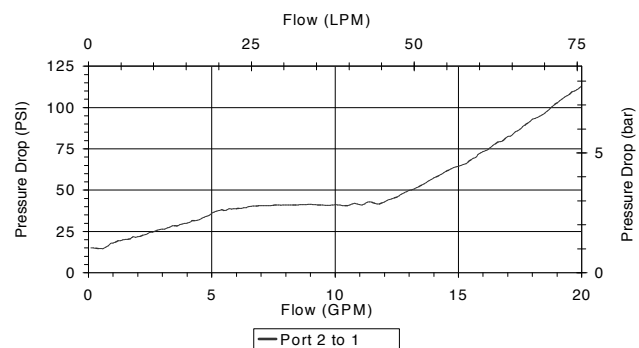
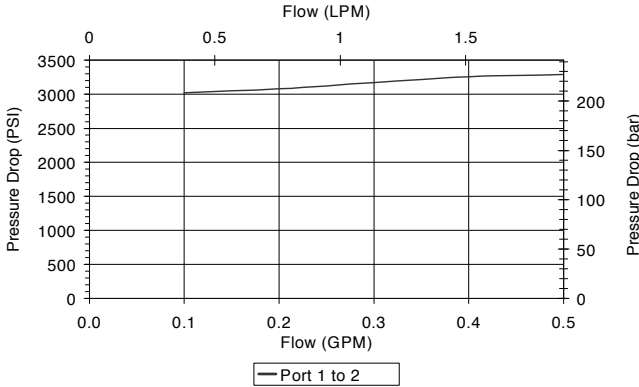

HYDRAULIC SYMBOL

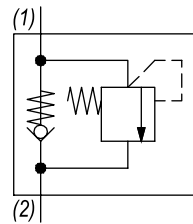

VALVE SPECIFICATIONS

Nominal Flow	15 GPM (57 LPM)
Rated Operating Pressure	4000 PSI (276 bar)
Typical Internal Leakage (150 SSU)	0-10 drops/min
Viscosity Range	36 to 3000 SSU (3 to 647 cSt)
Filtration	ISO 18/16/13
Media Operating Temp. Range	-40° to 250°F (-40° to 120°C)
Weight	.31 lbs (.14 kg)
Operating Fluid Media	General Purpose Hydraulic Fluid
Cartridge Torque Requirements	30 ft-lbs (40.6 Nm)
Cavity	DELTA 2W
Cavity Form Tool (Finishing)	40500000
Seal Kit	21191200

WARNING: the specifications/application data shown in our catalogs and data sheets are intended only as a general guide for the product described (herein). Any specific application should not be undertaken without independent study, evaluation, and testing for suitability.



4484 Boeing Drive Rockford, IL 61109 • USA • Phone +1 (815) 397-6628 • Fax +1 (815) 397-2526
mail: delta@delta-power.com • www.delta-power.com



Via Malavolti, 36 • 41122 Modena • ITALY • Phone +39 (059) 254895 • Fax +39 (059) 253512
mail: tecnord@tecnord.com • www.tecnord.com

DIMENSIONS

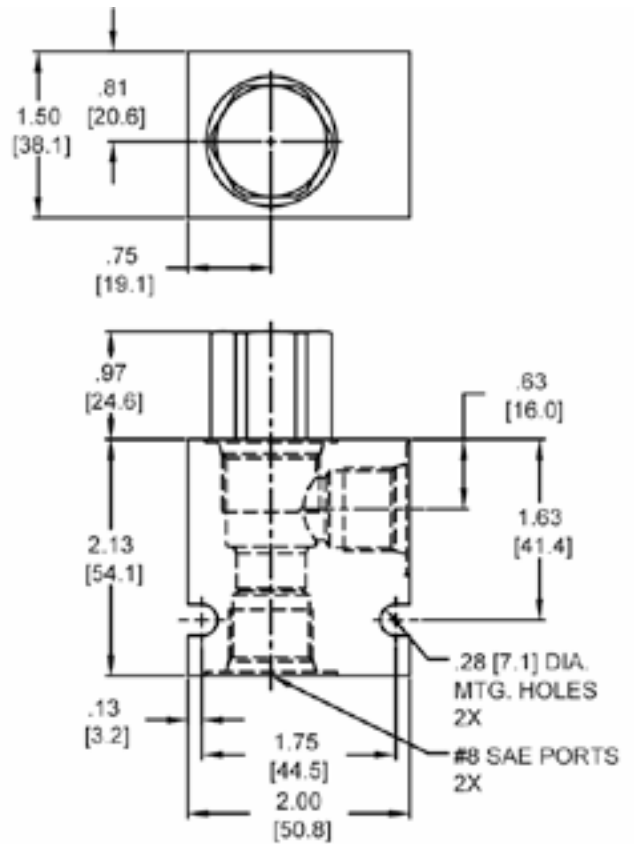
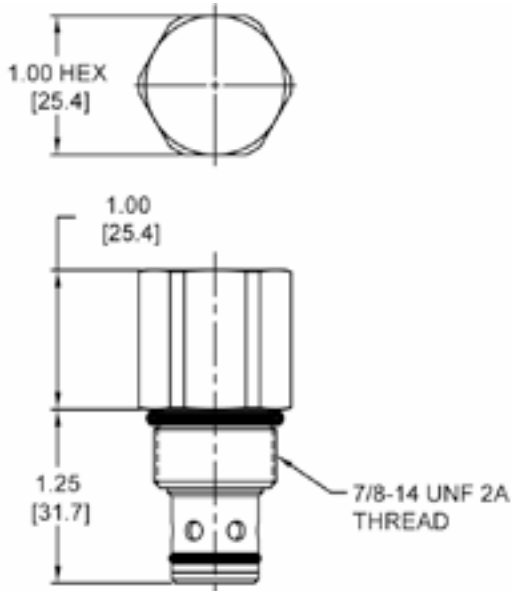

Body Weight: .47 lbs (.21 kg)

ORDERING INFORMATION

DE-CVT - - - -	
<p>OPTIONS</p> <p>Buna Standard 00</p> <p>Viton Standard V0</p>	<p>BODIES</p> <p>Blank Without Body</p> <p>N 3/8" NPTF Ports</p> <p>S #8 SAE Ports</p>
<p>PRESSURE SETTING</p> <p>1000 PSI 1</p> <p>2000 PSI 2</p> <p>3000 PSI 3</p> <p>4000 PSI 4</p>	<p>VOLTAGE</p> <p>0020 20 PSI</p> <p>0100 100 PSI</p> <p>± 10%</p>

WARNING
DO NOT USE ALUMINUM BODY
HIGH PRESSURE (4000 PSI) PRODUCT

W14 / 2018

WARNING: the specifications/application data shown in our catalogs and data sheets are intended only as a general guide for the product described (herein). Any specific application should not be undertaken without independent study, evaluation, and testing for suitability.



4484 Boeing Drive Rockford, IL 61109 • USA • Phone +1 (815) 397-6628 • Fax +1 (815) 397-2526
mail: delta@delta-power.com • www.delta-power.com



Via Malavolti, 36 • 41122 Modena • ITALY • Phone +39 (059) 254895 • Fax +39 (059) 253512
mail: tecnord@tecnord.com • www.tecnord.com