

**DE-FCA ADJUSTABLE FLOW CONTROL VALVE, PRESSURE COMPENSATED**

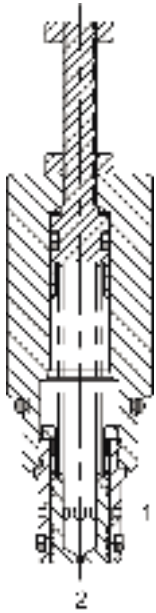

**DESCRIPTION**

10 size, 7/8-14 thread, "Delta" series, pressure compensated, flow control valve.

**OPERATION**

The DE-FCA maintains a constant flow rate out of (1) regardless of load pressure changes in the circuit downstream of (1). The adjustable control (see options for ranges) differential spring load can be set to customer flow specification. The valve begins to respond to load changes when the flow through the valve creates a pressure differential across the control orifice greater than 100 PSI (6.9 bar), with accurate flow maintenance from 100 to 3500 PSI (6.9 to 241 bar). Reverse flow (1) to (2) returns through the control orifice and is non-compensated. The regulated flow increases from low to high with clockwise rotation of the knob.

**FEATURES**

- Hardened parts for long life.
- Industry common cavity.
- Fine low-torque adjustment.



*Best stability is obtained with adjustment at highest flow.*

**HYDRAULIC SYMBOL**

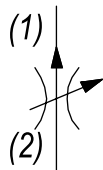

**PERFORMANCE**

Actual Test Data (Cartridge Only)

**VALVE SPECIFICATIONS**

Maximum Flow	8 GPM (30 LPM)
Rated Operating Pressure	3500 PSI (241 bar)
Viscosity Range	36 to 3000 SSU (3 to 647 cSt)
Filtration	ISO 18/16/13
Media Operating Temp. Range	-40° to 250°F (-40° to 120°C)
Weight	.49 lbs (.22 kg)
Operating Fluid Media	General Purpose Hydraulic Fluid
Cartridge Torque Requirements	30 ft-lbs (40.6 Nm)
Cavity	DELTA 2W
Cartridge Form Tool (Finishing)	40500000
Seal Kit	21191200

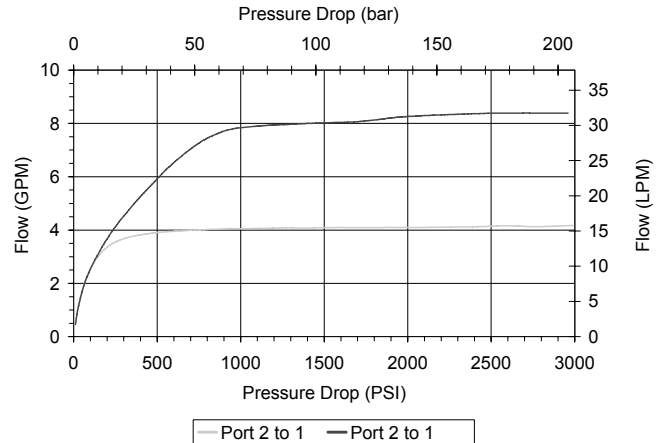
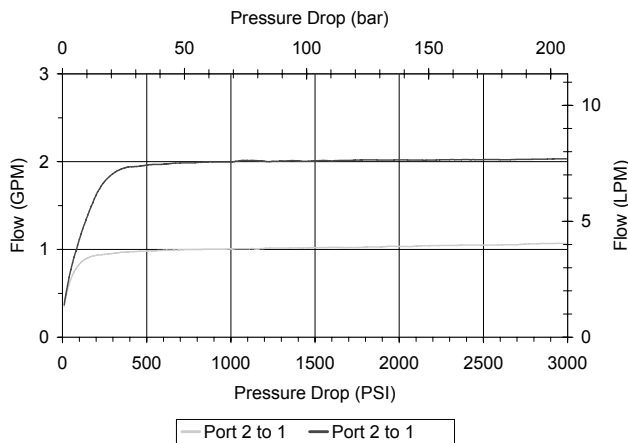

**WARNING:** the specifications/application data shown in our catalogs and data sheets are intended only as a general guide for the product described (herein). Any specific application should not be undertaken without independent study, evaluation, and testing for suitability.



4484 Boeing Drive Rockford, IL 61109 • USA • Phone +1 (815) 397-6628 • Fax +1 (815) 397-2526  
 mail: delta@delta-power.com • www.delta-power.com



Via Malavolti, 36 • 41122 Modena • ITALY • Phone +39 (059) 254895 • Fax +39 (059) 253512  
 mail: tecnord@tecnord.com • www.tecnord.com

**DIMENSIONS**

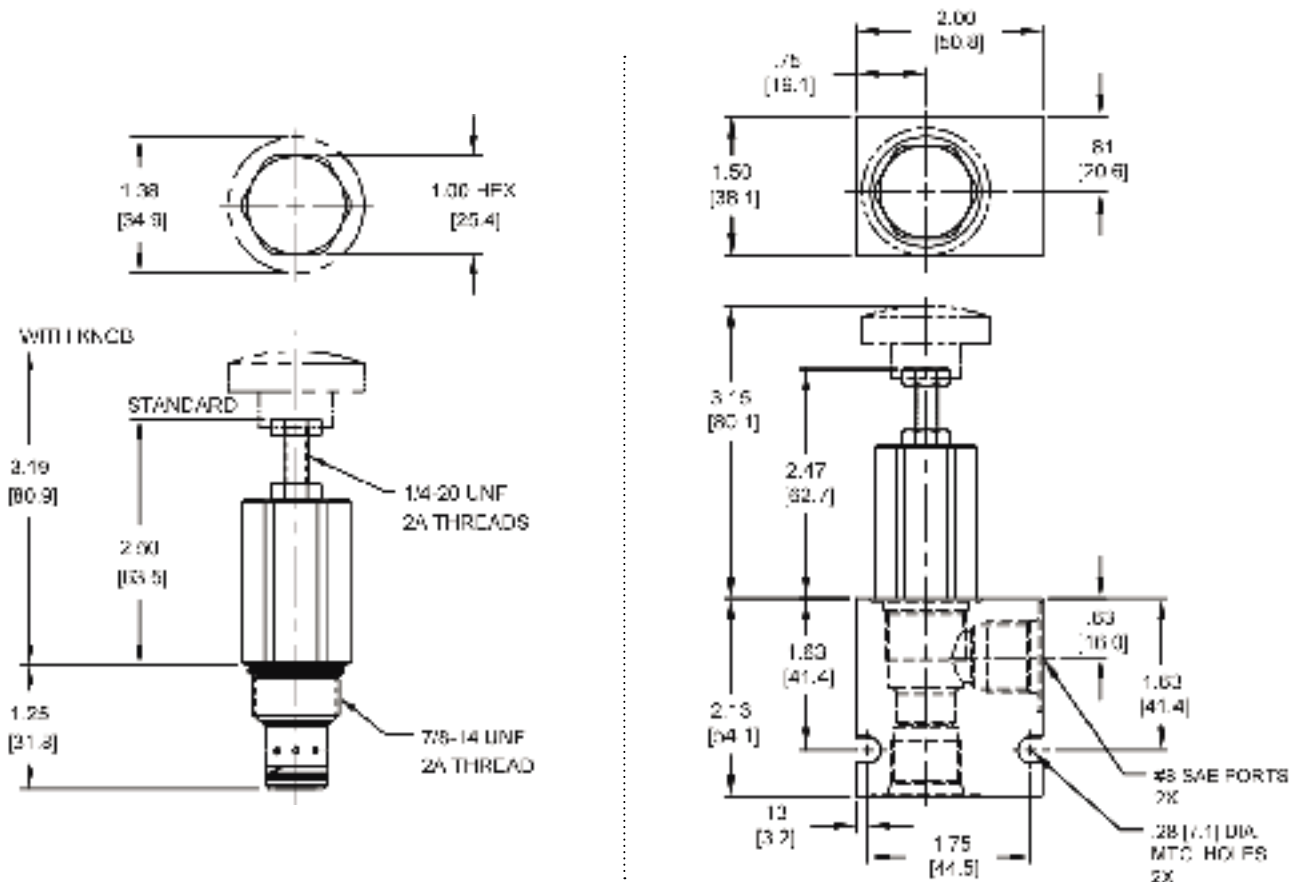

Body Weight: .47 lbs (.21 kg)

**ORDERING INFORMATION**

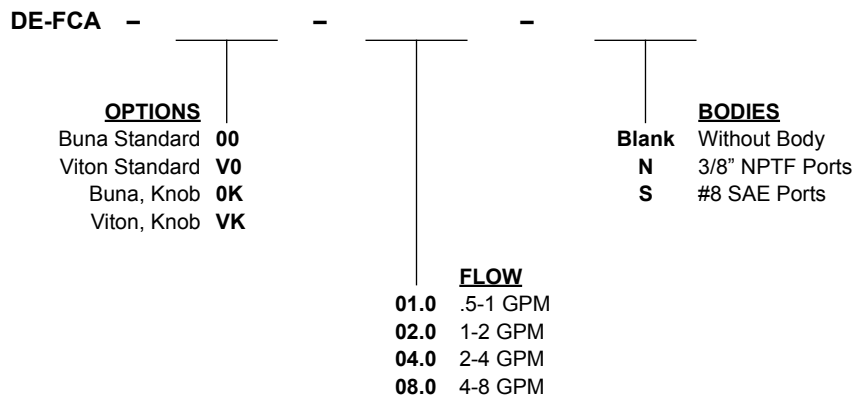

W6 / 2020

**WARNING:** the specifications/application data shown in our catalogs and data sheets are intended only as a general guide for the product described (herein). Any specific application should not be undertaken without independent study, evaluation, and testing for suitability.



4484 Boeing Drive Rockford, IL 61109 • USA • Phone +1 (815) 397-6628 • Fax +1 (815) 397-2526  
 mail: delta@delta-power.com • www.delta-power.com



Via Malavolti, 36 • 41122 Modena • ITALY • Phone +39 (059) 254895 • Fax +39 (059) 253512  
 mail: tecnord@tecnord.com • www.tecnord.com