

RC-SHW-_F 4/6-FUNCTIONS METER-IN SHW RADIO TRANSMITTER

DESCRIPTION

Single-hand radio controller (transmitter/transceiver) with CANbus interface. For use with Tecnord RX-CAN radio receivers or as stand-alone controller for CANbus based systems. RC-SHW-_F radio controller is designed to allow radio remote operation of machines equipped with a CAN-based control system. Its compact and ergonomic design allows easy operation: with a single hand all operators, on-off and proportional, are available. RC-SHW-_F standard configuration includes 4 or 6 toggle switches for on-off selection of the function(s) and one proportional trigger for proportional speed control. Additional operators are available for radio enable and auxiliary functions. A STOP push button is available to immediately stop the machine in case of hazard. Battery and battery charger are internal; a connector is provided for battery charging and backup cable communication. The transmission technology used allows high immunity to interference and long operating range. Co-existence between multiple radio units is also allowed. A unique code allows the RC-SHW-_F controller to operate only with its coupled radio receiver. Standard cable communication protocols include CANopen and J1939. Customized protocols are available for OEMs.

FEATURES

- Standard power supply from internal battery pack (rechargeable).
- Power supply line from the cable is protected against reversed polarity and overvoltage.
- CANbus line is protected against short circuits to GND and supply.
- Microprocessor based.
- Robust plastic enclosure.
- CE, FCC, IC certifications available
- Electro Magnetic Compatibility (EMC): EN 61000-6-2 (Immunity)
EN 61000-6-3 (Emissions)

SPECIFICATIONS

Operating voltage (internal battery):	4.7÷6 VDC
Operating voltage (serial cable):	8÷32 VDC
Max current consumption:	250 mA
Operating temperature:	-40 ÷ +85°C
Operating Frequency Band:	2402÷2480 MHz
Transmission type:	BT 2.1 + EDR
Antenna:	Built-in (internal)
Diagnostics:	1 LED for the controller's status (more LEDs available as option) 1 buzzer
CANbus physical layer:	ISO 11898
CANbus protocol:	J1939 (standard) CANopen (option)
Connector type:	M12, 4 pins
Housing material:	thermoplastic POM (different colours available)
Weight:	< 1Kg (4F)
Environmental protection:	IP 65



DIMENSIONS

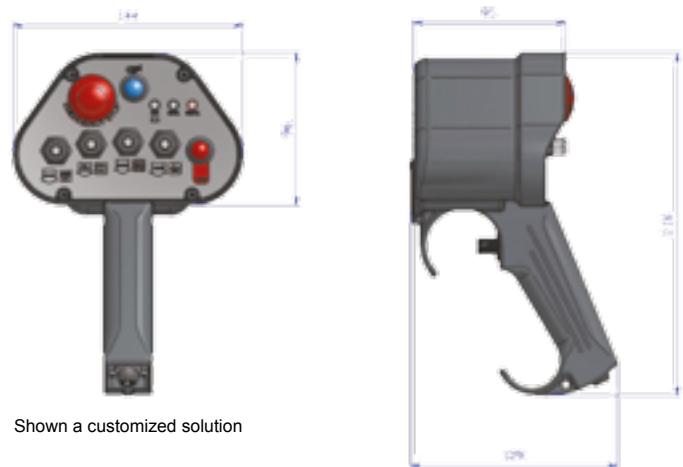

APPLICATIONS

- Remote control of aerial platforms, telehandlers, agricultural machines and lift equipment equipped with CANbus systems.
- Stand-alone CANbus controller in both 12 VDC and 24 VDC systems.

RC ORDERING INFORMATION: see page RC3

WARNING: the specifications/application data shown in our catalogs and data sheets are intended only as a general guide for the product described (herein). Any specific application should not be undertaken without independent study, evaluation, and testing for suitability.



4484 Boeing Drive Rockford, IL 61109 • USA • Phone +1 (815) 397-6628 • Fax +1 (815) 397-2526
mail: delta@delta-power.com • www.delta-power.com



Via Malavolti, 36 • 41122 Modena • ITALY • Phone +39 (059) 254895 • Fax +39 (059) 253512
mail: tecnord@tecnord.com • www.tecnord.com