

**SJ-S2C PILOT OPERATED POPPET, 2 WAY NORMALLY OPEN**

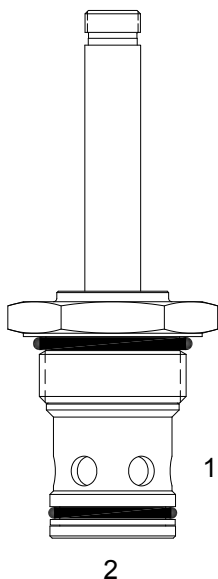

**DESCRIPTION**

16 size, 1 5/16-12 thread, "Super" series, solenoid operated, 2 way normally open, pilot operated poppet valve with free reverse flow energized.

**OPERATION**

When de-energized the SJ-S2C allows flow to pass from (1) to (2), but restricts flow from (2) to (1).  
When energized the valve blocks flow from (1) to (2) but allows free reverse flow from (2) to (1).

**FEATURES**

- Hardened parts for long life.
- Efficient wet-armature construction.
- Cartridges are voltage interchangeable.
- Industry common cavity.
- Unitized, molded coil design.
- Continuous duty rated solenoid.
- Optional coil voltages and terminations.
- Optional "I" Coil: Weatherproof, Thermal Shock, Immersion Safe.

**HYDRAULIC SYMBOL**

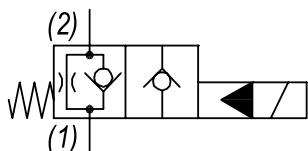

**PERFORMANCE**

Actual Test Data (Cartridge Only)

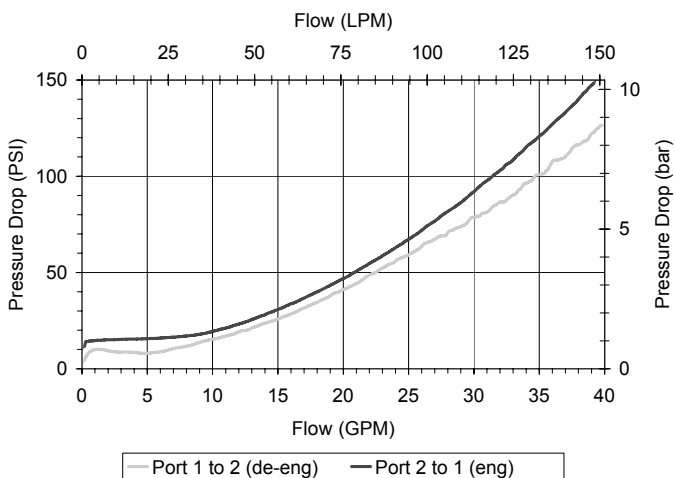

**VALVE SPECIFICATIONS**

Nominal Flow	40 GPM (151 LPM)
Rated Operating Pressure	3000 PSI (207 bar)
Typical Internal Leakage (150 SSU)	0-10 drops/min
Viscosity Range	36 to 3000 SSU (3 to 647 cSt)
Filtration	ISO 18/16/13
Media Operating Temp. Range	-40° to 250°F (-40° to 120°C)
Weight	.74 lbs (.33 kg)
Operating Fluid Media	General Purpose Hydraulic Fluid
Cartridge Torque Requirements	90 ft-lbs (122 Nm)
Coil Nut Torque Requirements	4-6 ft-lbs (5.4-8.1 Nm)
Cavity	SUPER 2W
Cavity Tools Kit	
(form tool, reamer, tap)	40500017
Seal Kit	21191400

**WARNING:** the specifications/application data shown in our catalogs and data sheets are intended only as a general guide for the product described (herein). Any specific application should not be undertaken without independent study, evaluation, and testing for suitability.



4484 Boeing Drive Rockford, IL 61109 • USA • Phone +1 (815) 397-6628 • Fax +1 (815) 397-2526  
mail: delta@delta-power.com • www.delta-power.com



Via Malavolti, 36 • 41122 Modena • ITALY • Phone +39 (059) 254895 • Fax +39 (059) 253512  
mail: tecnord@tecnord.com • www.tecnord.com

**DIMENSIONS**

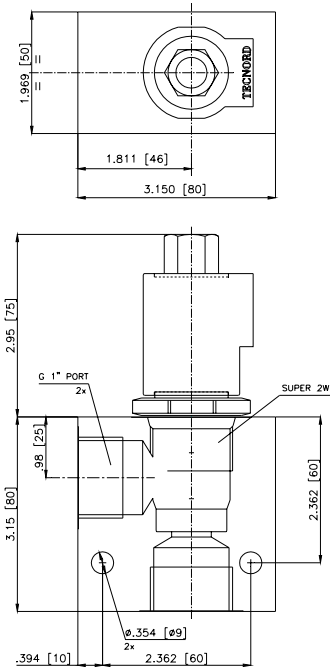
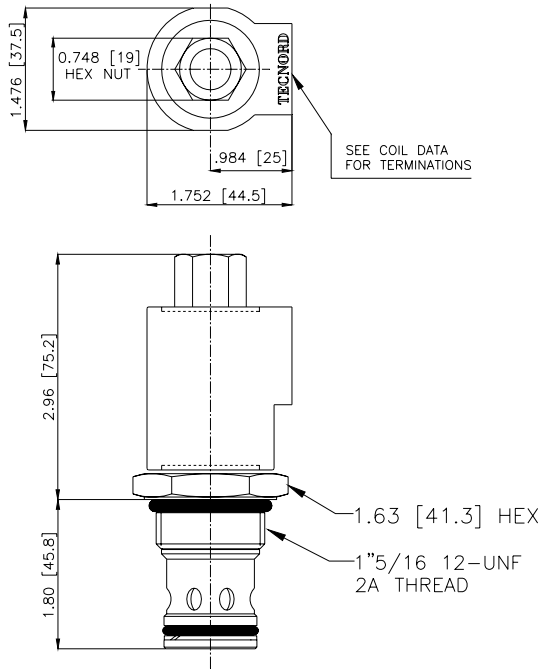

**ORDERING INFORMATION**

Approximate Coil Weight: .56 lbs (.25 kg)

**SJ-S2C** - - - -

- OPTIONS**
- Buna Standard **00**
  - Viton Standard **V0**
  - Buna, Screen **A0**
  - Viton, Screen **W0**

- BODIES**
- Blank Without Body
  - N** 1" BSP Ports
  - S** #12 SAE Ports

**Note: use screen only if flow direction is from (1) to (2)**

- VOLTAGE** (other voltages available on request)
- 12** 12 VDC
  - 24** 24 VDC
  - 22** 220 VAC without internal rectifier

**"V" COIL TERMINATION**  
(All DC Except as Noted)

**DL** Double Lead  
(several types of termination can be attached on leads on request)

**HC** DIN 43650 (Hirschmann) - (AC&DC)  
**DI** Deutsch - Integral DT04-2P

**IMMERSION PROOF "D" TYPE**

- DIA** "1" Coil AMP Superseal - Integral
- DID** "1" Coil Deutsch - Integral DT04-2P
- DIJ** "1" Coil AMP Jr. Timer - Integral
- DIM** "1" Coil Metri-Pack - Integral

W 9 / 2020

**WARNING:** the specifications/application data shown in our catalogs and data sheets are intended only as a general guide for the product described (herein). Any specific application should not be undertaken without independent study, evaluation, and testing for suitability.



4484 Boeing Drive Rockford, IL 61109 • USA • Phone +1 (815) 397-6628 • Fax +1 (815) 397-2526  
mail: delta@delta-power.com • www.delta-power.com



Via Malavolti, 36 • 41122 Modena • ITALY • Phone +39 (059) 254895 • Fax +39 (059) 253512  
mail: tecnord@tecnord.com • www.tecnord.com