

DG-FDT FLOW DIVIDER / COMBINER VALVE, SPOOL TYPE

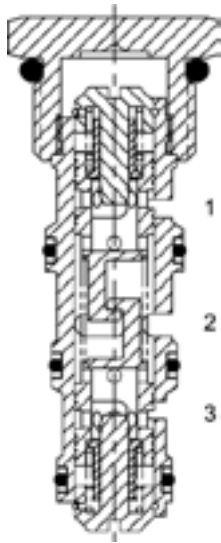

DESCRIPTION

10 size, 7/8-14 thread "Delta Series", spool type, flow divider/combiner, positive traction valve.

OPERATION

In the dividing mode, the DG-FDT will divert input flow from port (2) to ports (3) and (1), based on the ratio specified, regardless of operating pressure. The DG-FDT will combine input flows from ports (3) and (1). Should circuit operation result in a blockage of either (3) or (1), the opposite port may also close under certain conditions. Should this potential exist, consult the factory.

FEATURES

- Hardened parts for long life.
- Industry common cavity.



*DO NOT EXCEED MAXIMUM FLOW PER MODEL
Use where wheel slip (or "drag") needs to be accomplished.*



*TRACTION FLOW W/1 LEG UNLOADED
2-3 GPM valve - 0.4 GPM
3-6 GPM valve - 0.7 GPM
6-9 GPM valve - 1.1 GPM
9-12 GPM valve - 1.5 GPM*

HYDRAULIC SYMBOL

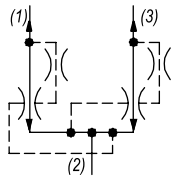

PERFORMANCE

Actual Test Data (Cartridge Only)

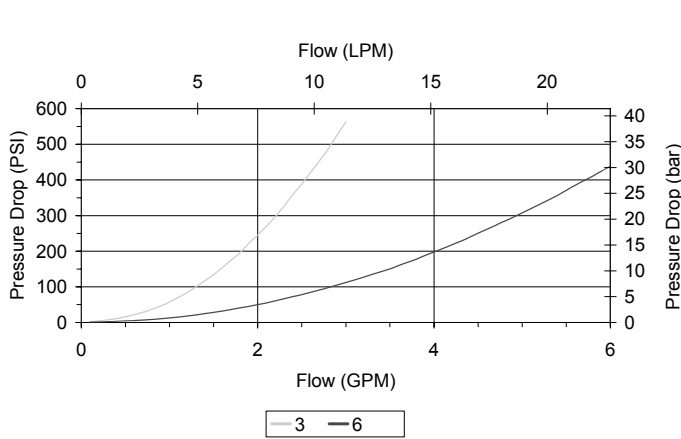

VALVE SPECIFICATIONS

Maximum Flow	12 GPM (45 LPM)
Accuracy on Flow Splits	±10% of Max Rated Inlet Flow
Maximum Operating Pressure	3500 PSI (241 bar)
Viscosity Range	36 to 3000 SSU (3 to 647 cSt)
Filtration	ISO 18/16/13
Media Operating Temp. Range	-40° to 250°F (-40° to 120°C)
Weight	.22 lbs (.10 kg)
Operating Fluid Media	General Purpose Hydraulic Fluid
Cartridge Torque Requirements	30 ft-lbs (40.6 Nm)
Cavity	DELTA 4W
Cavity Form Tool (Finishing)	40500002
Seal Kit	21191214

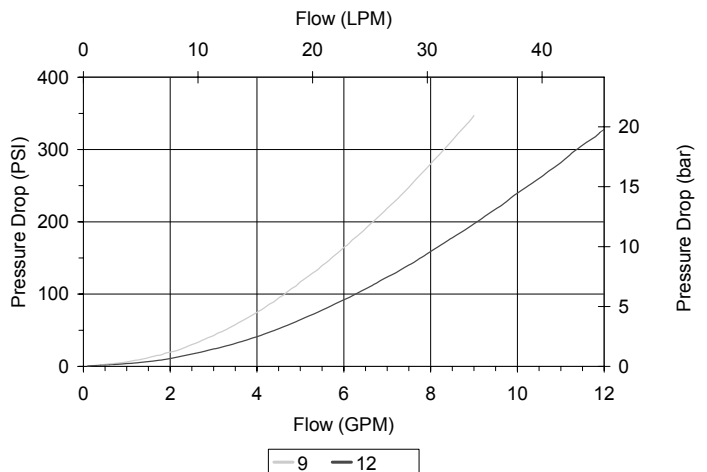

WARNING: the specifications/application data shown in our catalogs and data sheets are intended only as a general guide for the product described (herein). Any specific application should not be undertaken without independent study, evaluation, and testing for suitability.



4484 Boeing Drive Rockford, IL 61109 • USA • Phone +1 (815) 397-6628 • Fax +1 (815) 397-2526
mail: delta@delta-power.com • www.delta-power.com



Via Malavolti, 36 • 41122 Modena • ITALY • Phone +39 (059) 254895 • Fax +39 (059) 253512
mail: tecnord@tecnord.com • www.tecnord.com

DIMENSIONS

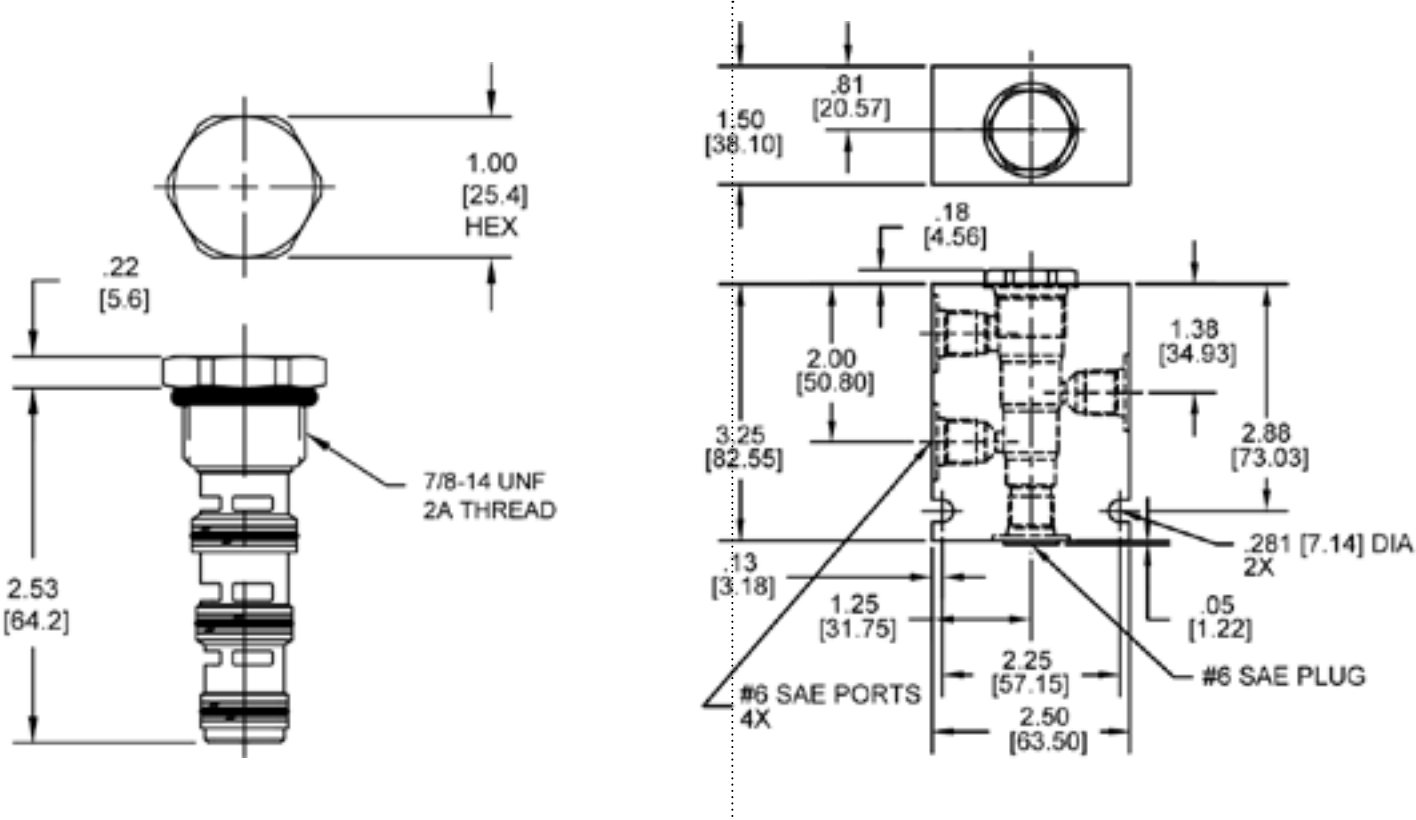

Body Weight: .99 lbs (.45 kg)

ORDERING INFORMATION

<p>OPTIONS</p> <p>Buna Standard 00</p> <p>Viton Standard V0</p>		<p>SPLITS</p> <p>50-50 50</p> <p>Consult factory for splits other than 50-50</p>		<p>INLET FLOW</p> <p>03 2-3 GPM</p> <p>06 3-6 GPM</p> <p>09 6-9 GPM</p> <p>12 9-12 GPM</p>		<p>BODIES</p> <p>Blank Without Body</p> <p>N 1/4" NPT Ports</p> <p>S #6 SAE Ports</p> <p>Note: must use 4-way body</p>	
--	--	---	--	---	--	--	--

W6 / 2020 **WARNING:** the specifications/application data shown in our catalogs and data sheets are intended only as a general guide for the product described (herein). Any specific application should not be undertaken without independent study, evaluation, and testing for suitability.



4484 Boeing Drive Rockford, IL 61109 • USA • Phone +1 (815) 397-6628 • Fax +1 (815) 397-2526
 mail: delta@delta-power.com • www.delta-power.com



Via Malavolti, 36 • 41122 Modena • ITALY • Phone +39 (059) 254895 • Fax +39 (059) 253512
 mail: tecnord@tecnord.com • www.tecnord.com