

**PP-FCP FIXED PRIORITY FLOW CONTROL VALVE**

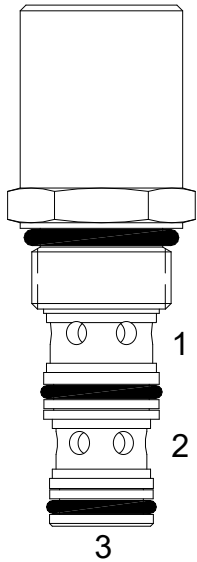

**DESCRIPTION**

8 size, 3/4-16 thread, "Power" series, fixed priority flow control valve.

**OPERATION**

The PP-FCP allows pressure compensated flow from (3) to (1) regulated by the pressure present at (3). Excess flow bypasses out (2).

**FEATURES**

- Hardened parts for long life.
- Industry common cavity.



Test data shown on this sheet, for condition of port (2) to tank. Data on next page, for condition of port (3) to tank.

**HYDRAULIC SYMBOL**

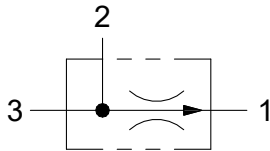

**PERFORMANCE**

Actual Test Data (Cartridge Only)

**VALVE SPECIFICATIONS**

Maximum Flow	5 GPM (19 LPM)
Rated Operating Pressure	3500 PSI (241 bar)
Viscosity Range	36 to 3000 SSU (3 to 647 cSt)
Filtration	ISO 18/16/13
Media Operating Temp. Range	-40° to 250°F (-40° to 120°C)
Weight	.56 lbs (.25 kg)
Operating Fluid Media	General Purpose Hydraulic Fluid
Cartridge Torque Requirements	25 ft-lbs (34 Nm)
Cavity	POWER 3W
Cavity Form Tool (Finishing)	40500024
Seal Kit	21191106

**WARNING:** the specifications/application data shown in our catalogs and data sheets are intended only as a general guide for the product described (herein). Any specific application should not be undertaken without independent study, evaluation, and testing for suitability.



4484 Boeing Drive Rockford, IL 61109 • USA • Phone +1 (815) 397-6628 • Fax +1 (815) 397-2526  
 mail: delta@delta-power.com • www.delta-power.com



Via Malavolti, 36 • 41122 Modena • ITALY • Phone +39 (059) 254895 • Fax +39 (059) 253512  
 mail: tecnord@tecnord.com • www.tecnord.com

**DIMENSIONS**

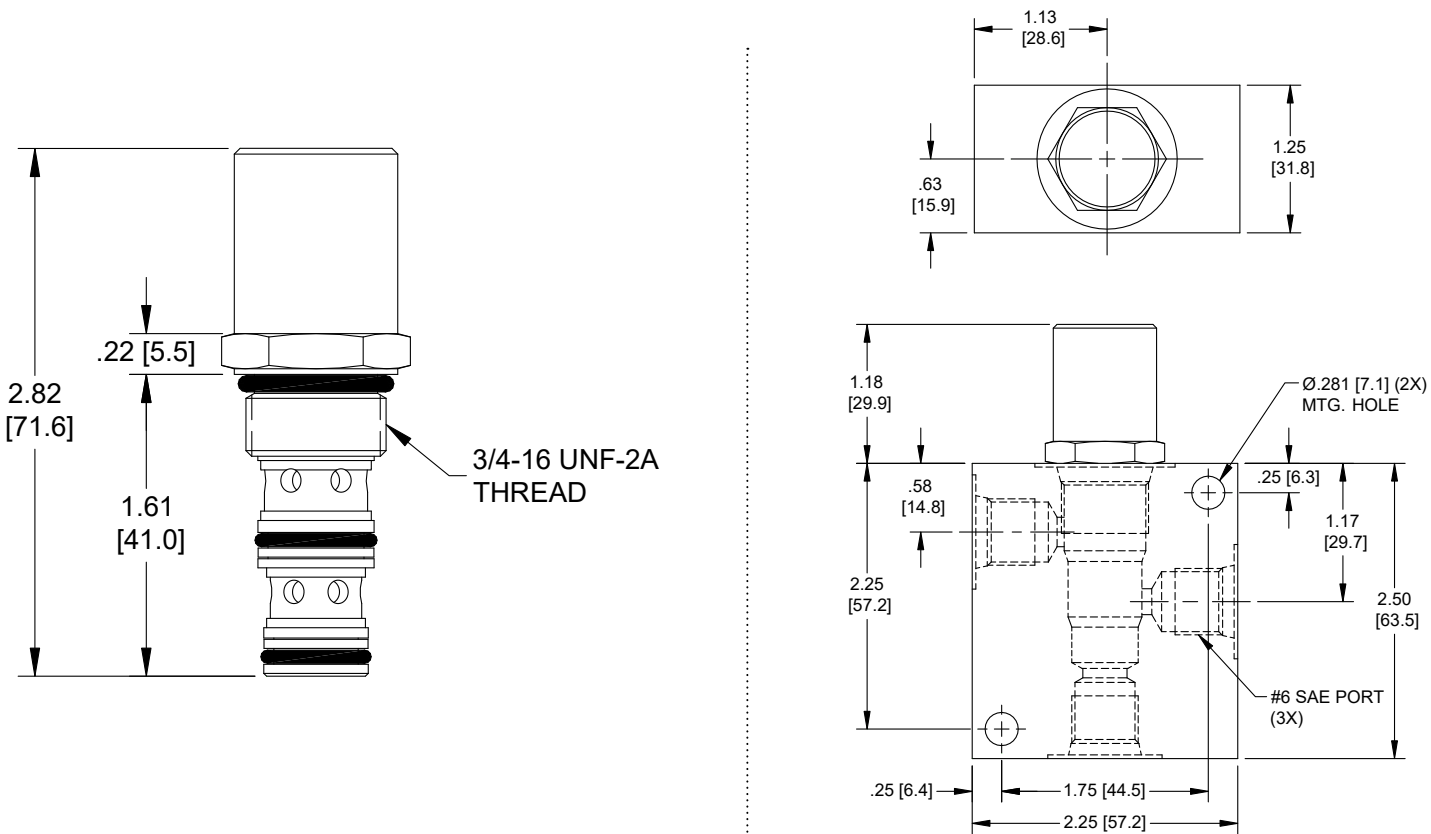

Body Weight: .56 lbs (.25 kg)

**ORDERING INFORMATION**

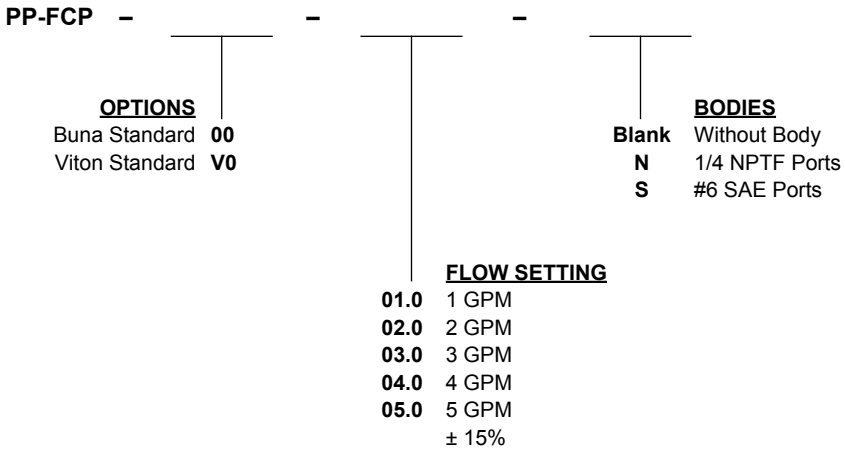

WARNING: the specifications/application data shown in our catalogs and data sheets are intended only as a general guide for the product described (herein). Any specific application should not be undertaken without independent study, evaluation, and testing for suitability.



4484 Boeing Drive Rockford, IL 61109 • USA • Phone +1 (815) 397-6628 • Fax +1 (815) 397-2526  
 mail: delta@delta-power.com • www.delta-power.com



Via Malavolti, 36 • 41122 Modena • ITALY • Phone +39 (059) 254895 • Fax +39 (059) 253512  
 mail: tecnord@tecnord.com • www.tecnord.com